



TECHNICAL DATA:

Easily accessible device,
according to standard EN 1176-1:2017

Device dimensions: 0,45 x 0,80m
 Device height: 0,74m
 Minimum space: 3,45 x 3,80m
 Falling area: 11,17m²
 Critical fall height: 0,57m
 Foundations depth: -0,60m

Top view with impact area

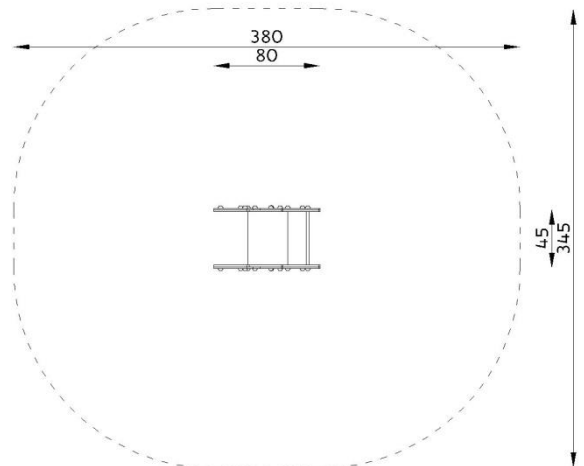

The device according to EN 1176-1:2017
 Playground equipment and surfacing – Part 1:
 General safety requirements and test methods

Safety surfaces:
 - turf/topsoil, sand, gravel, bark, synthetic surface
 - minimal thickness for loose particulate materials 200+100mm
 - synthetic surface according to critical fall height

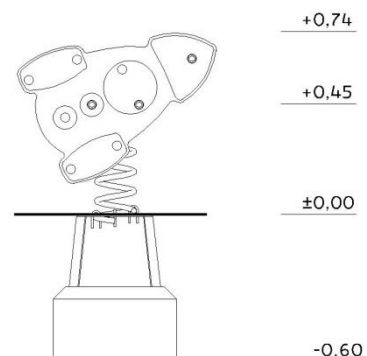

MATERIALS:

Flat elements:	HDPE sheets
Foundation base:	openwork steel construction
Handles, legs suport:	stainless steel
Spring:	galvanized steel, powder painted
Steel elements:	galvanized steel, powder painted
Caps:	plastic
Foundations:	concrete min. C12/15 standard



SATERNUS DISTRIBUTION Sp. z o.o. sp.k.
ul. Nowa 32
41-500 Chorzów, Poland

Certificate beholder:
Producer:
Distributor:

GRUPA SATERNUS Sp. z o.o. S. K. A. reserves all rights to protect copyright under the Act of February 4, 1994 on Copyright and Related Rights (Journal of Laws No. 28, pc 83), and in particular Art. 78 and 79 of this Law.

GRUPA SATERNUS Sp. z o.o. S. K. A.
Saternus Production Sp. z o.o. sp. k.
Saternus Distribution Sp. z o.o. sp. k.