

## TECHNICAL DATA:

Easily accessible device,  
according to standard EN 1176-1:2017

Device dimensions:	2,76 x 0,89m
Device height:	0,35m
Minimum space:	-
Falling area:	-
Critical fall height:	-
Foundations depth:	-0,60m

The device according to EN 1176-1:2017  
Playground equipment and surfacing – Part 1:  
General safety requirements and test methods

Safety surfaces:  
- paved, turf/topsoil, sand, gravel, bark, synthetic surface  
- minimal thickness for loose particulate materials 200+100mm  
- synthetic surface according to critical fall height

### Top view with falling area

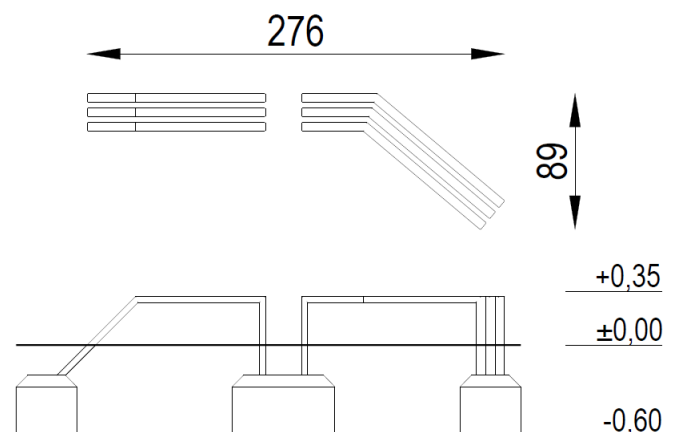

## COMPONENTS:

Bench - module 1 set

## MATERIALS:

Construction poles:

stainless steel profiles

Foundations:

concrete min. C12/15 standard



SATERNUS DISTRIBUTION Sp. z o.o. sp.k.  
ul. Nowa 32  
41-500 Chorzów, Poland

Certificate beholder:  
Producer:  
Distributor:

GRUPA SATERNUS Sp. z o.o. S. K. A. reserves all rights to protect copyright under the Act of February 4, 1994 on Copyright and Related Rights (Journal of Laws No. 28, item 83), and in particular Art. 78 and 79 of this Law.

GRUPA SATERNUS Sp. z o.o. S. K. A.  
Saternus Production Sp. z o.o. sp. k.  
Saternus Distribution Sp. z o.o. sp. k.