

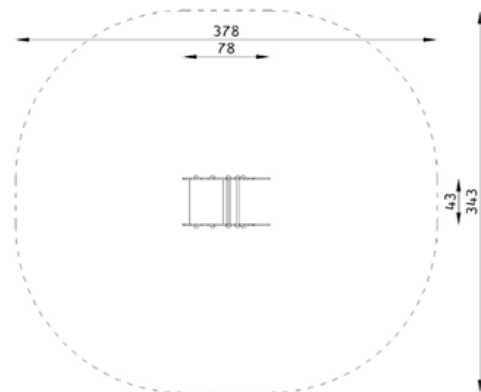

## TECHNICAL DATA:

### Top view with falling area

<b>Device dimensions:</b>	0,43m x 0,78m
<b>Device height:</b>	0,81m
<b>Minimum space:</b>	3,78 x 3,43m
<b>Falling area:</b>	0,60m
<b>Critical fall height:</b>	11,00m <sup>2</sup>
<b>Depth of foundations:</b>	-0,60m



The device according to EN 1176-1:2012  
Playground equipment and surfacing – Part 1:  
General safety requirements and test methods.

### Safety surfaces:

- turf/topsoil, sand, gravel, bark, synthetic surface
- minimal thickness for loose particulate materials 200+100mm
- synthetic surface according to critical fall height

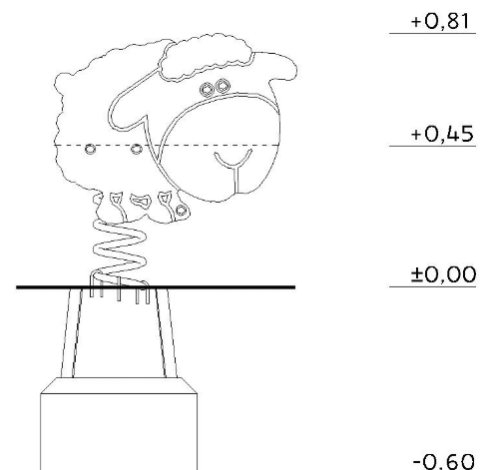

## MATERIALS:

<b>Decorative elements:</b>	HDPE sheet
<b>Handles, leg supports:</b>	stainless steel pipes
<b>Steel elements:</b>	galvanized steel, powder coated
<b>Spring:</b>	spring steel, galvanized and powder coated in gray
<b>Caps:</b>	plastic
<b>Foundation base:</b>	steel structure
<b>Foundations:</b>	concrete class min. C12/15



GRUPA SATERNUS S.A.  
ul. Nowa 32  
41-500 Chorzów, Poland

Certificate beholder:  
Producer:  
Distributor:

GRUPA SATERNUS S.A. reserves all rights to protect copyright  
Under the Act of February 4, 1994 on Copyright and Related Rights  
(Journal of Laws No. 28, pc 83), and in particular Art. 78 and 79 of this Law.

GRUPA SATERNUS S.A.  
Saternus Production Sp. z o.o. sp. k.  
Saternus Distribution Sp. z o.o. sp. k.