



**TECHNICAL DATA:**

Easily accessible device,  
according to standard EN 1176-1 : 2017

Device dimensions: 3,50 x 2,10m  
 Device height: 2,40m  
 Minimum space: 3,50 x 7,40m  
 Falling area: 25,90m<sup>2</sup>  
 Critical fall height: 1,25m  
 Foundations depth: -0,60m

**Projection and device view**

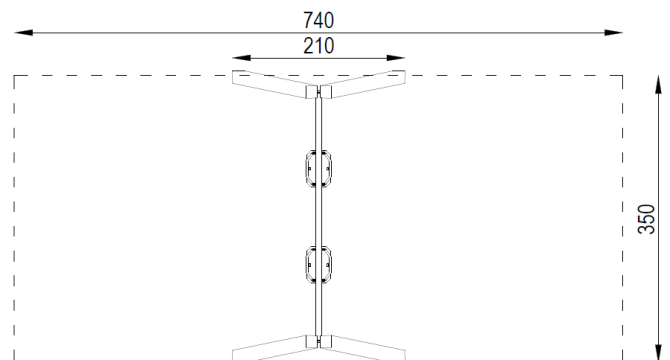

The device according to EN 1176-1 : 2017  
 Playground equipment and surfacing – Part 1:  
 General safety requirements and test methods.

Safety surfaces:  
 - sand, gravel, bark, synthetic surface  
 - minimal thickness for loose particulate materials 200+100mm  
 - synthetic surface according to critical fall height

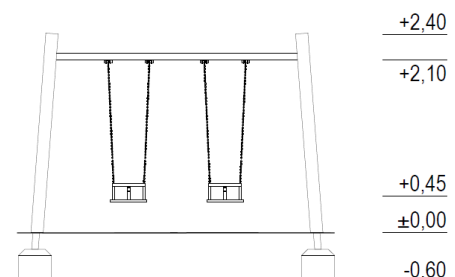

## COMPONENTS:

Supporting structure 1 set  
Basket seat 2 pcs

## MATERIALS:

Construction poles: recycled material  
Steel elements: galvanized steel, powder coated  
Basket seat: made of steel construction,  
coated with rubber  
Chain: stainless steel, calibrated  
Caps: plastic  
Foundations: concrete min. C12/15 standard



SATERNUS DISTRIBUTION Sp. z o.o. sp.k.  
ul. Nowa 32  
41-500 Chorzów, Poland

Certificate beholder:  
Producer:  
Distributor:

GRUPA SATERNUS Sp. z o.o. S. K. A. reserves all rights to protect copyright under the Act of February 4, 1994 on Copyright and Related Rights (Journal of Laws No. 28, pc 83), and in particular Art. 78 and 79 of this Law.

GRUPA SATERNUS Sp. z o.o. S. K. A.  
Saternus Production Sp. z o.o. sp. k.  
Saternus Distribution Sp. z o.o. sp. k.