



**TECHNICAL DATA:**

Easily accessible device,  
according to standard EN 1176-1 : 2017

Device dimensions:	3,00 x 0,43m
Device height:	0,95m
Minimum space:	5,00 x 2,50m
Falling area:	11,64m <sup>2</sup>
Critical fall height:	0,91m
Foundations depth:	-0,60m

**Projection and device view**

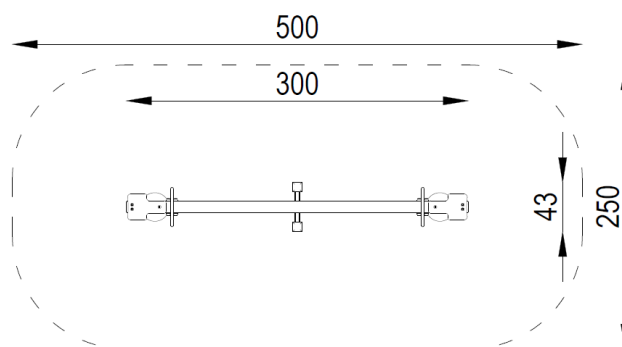

The device according to EN 1176-1 : 2017  
Playground equipment and surfacing – Part 1:  
General safety requirements and test methods.

- Safety surfaces:
- turf/topsoil, sand, gravel, bark, synthetic surface
  - minimal thickness for loose particulate materials 200+100mm
  - synthetic surface according to critical fall height

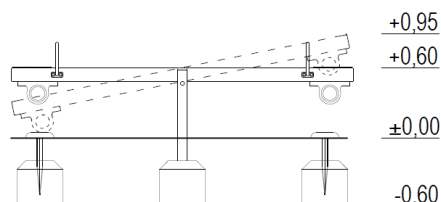

## MATERIALS:

Construction:	galvanized steel
Horizontal beam:	recycled material
Grips:	galvanized steel, powder coated
Seat:	recycled material
Bumper:	made of rubber granulate
Caps:	plastic
Foundations:	concrete min. C12/15 standard



SATERNUS DISTRIBUTION Sp. z o.o. sp.k.  
ul. Nowa 32  
41-500 Chorzów, Poland

Certificate beholder:  
Producer:  
Distributor:

GRUPA SATERNUS Sp. z o.o. S. K. A. reserves all rights to protect copyright under the Act of February 4, 1994 on Copyright and Related Rights (Journal of Laws No. 28, pc 83), and in particular Art. 78 and 79 of this Law.

GRUPA SATERNUS Sp. z o.o. S. K. A.  
Saternus Production Sp. z o.o. sp. k.  
Saternus Distribution Sp. z o.o. sp. k.